

BOMAG

FAYAT GROUP

Tackwagon

TW500



■ *A Quality Product Built To Meet
And Exceed The Customer's Demands.*

KEY FEATURES

- Heavy duty 12 GPM pump driven by a 5.5 hp Honda gas engine.
- 500 Gallon primary tank capacity.
- 10" fill spout and lid that seals and locks down.
- 40 feet of 1/2" hose on a heavy duty reel producing a work area 80 feet wide.
- 6' wand made of lightweight aluminum complete with replaceable tip.
- 9 gallon flush tank and 11 gallon waste tank



Technical Specifications

TW500

Shipping dimensions
in cubic feet (m³)

TW500 513 (14.5)

Standard Equipment

- 5.5 hp Honda engine
- Direct drive asphalt pump
(12 GPM)
- 500 gallon primary tank capacity
- 2 - 3500 lb GVW axles with electric
trailer brakes with safety disconnect
- Trailer safety chains
- Adjustable hitch with swivel tongue
mounted jack
- Two each 50,000 btu vapor propane
burners and hand held starter torch
- Single propane bottle holder
and regulator
- 9 gallon solvent flushing reservoir
- 11 gallon waste reservoir
- 6 foot aluminum spray wand
(lightweight)
- Hose Reel with 40 foot 1/2" hose
- 10" filler lid and 2" draincock
- Material temperature Thermometer
- Adjustable Relief Valve to obtain
desired spraying pressure and volume

Optional Equipment

- 9 foot width spray bar assembly with
waste tank
- Overnight 110 volt electric heater
- 9 hp Electric start engine
- Cab controlled (remote) electric
on/off for spray bar assembly

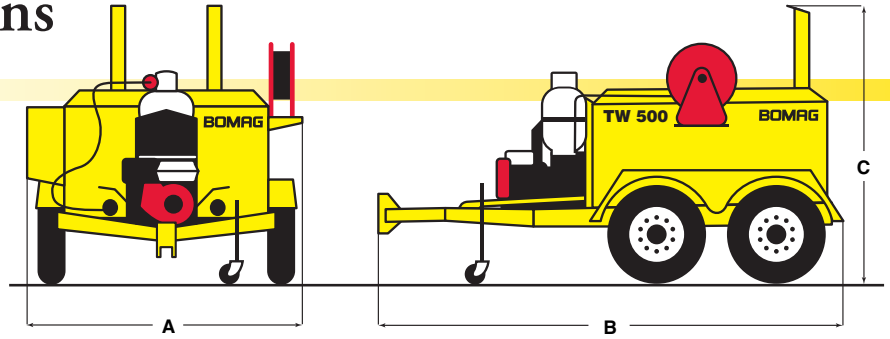

DIMENSIONS IN INCHES (MM)

	A	B	C
TW500	81 (2057)	137 (3480)	80 (2032)

Technical data

Weights

Dry Weight.....	lbs (kg)
Loaded Weight	lbs (kg)

Dimensions

Length	in (mm)
Width	in (mm)
Overall Height.....	in (mm)
Tank Height	in (mm)
Loading Height.....	in (mm)

Pump:

Delivery	gpm (lpm)
Type.....	
Speed	rpm

Tires:

Size	
Load Range.....	
Quantity on Machine	

Drive:

Engine Type.....	
Model.....	
Performance SAE J1349	hp (kW)
Fuel	

Service Capacities:

Fuel	gal (l)
Engine Oil.....	qts (l)

Trackwagon TW500

2500	(1134)
7000	(3175)

137	(3480)
81	(2057)
80	(2032)
24	(610)
51	(1295)

12	(45.4)
Direct Drive	
3600	

225/75R15
D
4

Honda	
GX160	
5.5	(4.1)
Gas	

1	(3.6)
.6	(.6)

Technical modifications reserved. Machines may be shown with options.