



99 SAE NET HORSEPOWER

C

CRAWLER LOADER

605C





# Best of both worlds.

Whether you're excavating, loading trucks, back-filling, or landscaping, the new 605C Crawler Loader delivers the performance and versatility you need to make it happen. Neither too big nor too small, this "right-size" rear-engine loader combines the comfort, convenience,

and durability of our larger C-Series-II Loaders, with the highly reliable job-proven drivetrain of the 650J. With unsurpassed power, weight, bucket capacity, breakout force, and tipping load, the new 605C is the productivity and uptime leader in its class. And beyond.



Best-in-class visibility provides a virtually unobstructed view of the bucket and surrounding jobsite for productivity-enhancing confidence and control.

Power turns, power management, infinite speed control — John Deere introduced them all 30 years ago. The 605C provides all of these productivity- and uptime-boosting advantages. And more.

Fuel-efficient high-torque 4.5-L turbocharged PowerTech™ John Deere diesel delivers power without compromise.

V-pattern FNR lever with steering pedals, or joystick? The choice is up to you. Both provide smooth, predictable travel speed and directional control, even on rough terrain.

Deere's unique Total Machine Control (TMC™) lets an operator customize operating characteristics and response, and even records machine usage.

Extended service intervals, remote test ports, and advanced diagnostic messaging maximize uptime and productivity.

Sealed and lubricated undercarriage is also available with SC-2™ bushings, for extended life in highly abrasive terrain conditions.

### Specifications

605C

99 horsepower

1.7-cu.-yd. bucket

22,480-lb. bucket breakout force

14,750-lb. static tipping load

23,600-lb. operating weight

Infinitely variable range from standstill to 5.5 mph lets an operator choose the right ground speed for the job. Speed range can also be modified for specific applications or terrain conditions, and even limited to maximize undercarriage life.

With optimal center of gravity, high ground clearance, and plenty of track on the ground, the 605C is exceptionally agile.

TMC allows maximum flexibility and control, letting you customize machine operation and response to personal preferences.

Electronically controlled hydrostatic drivetrain and pilot-operated boom and bucket provide low-effort predictable response at all times, in all conditions.



1

1. Nothing opens things up like the 605C's counterrotating tracks that provide space-saving spot turns. Usable counterrotation is a Deere advantage that also works well for overcoming heavy corner loads and for quickly repositioning the bucket on the go.



2

2. Infinitely variable track control lets you speed up or slow power to either track, for smooth maneuverability and nimble agility around structures.



3

3. The 605C takes the guesswork out of efficient operation. Simply set maximum desired ground speed and the crawler does the rest. As loads change, the drivetrain automatically powers up or down to maintain peak engine and power efficiency.



4

4. Want to put even more work within reach? Equip your 605C with a multipurpose bucket for loading, bulldozing, spreading material, and handling cumbersome objects.





# Take productivity to another level.

Others may offer hydrostatic drivetrains in their loaders. But no other comparable-size crawler even comes close to delivering the performance and exceptionally smooth moves you get with the 605C. Power turns, counterrotation, infinitely variable travel

speeds — this new loader puts your operator in complete command of a whole arsenal of highly productive advantages. Enables you to customize machine operation and response to personal preferences for maximum productivity, too.



# Seeing is believing.

It's easy to see why your operators will get more done in this loader. The 605C's rear-engine configuration allows best-in-class forward visibility. Even with cab, the wide expanse of tinted glass allows a commanding view of the bucket and surrounding jobsite.

There's plenty of wide-open space inside, too, with expansive entryways, substantial legroom, and generous storage. And like all Deere crawlers, low-effort ergonomically correct controls deliver uncommon operating ease. With unsurpassed results.

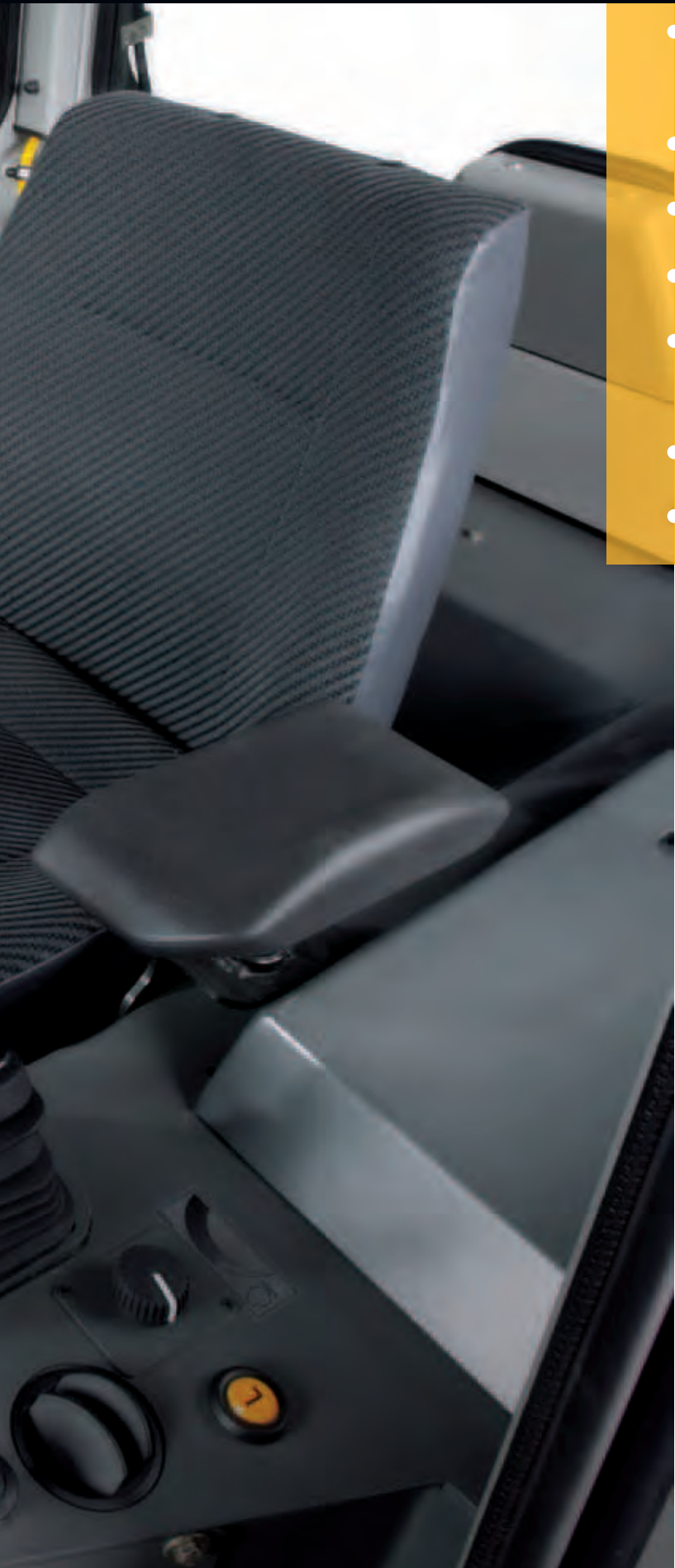

Unlike the cramped quarters on other crawlers, the 605C's available cab is spacious, quiet, and comfortable. Its 24,000-Btu HVAC system and roll shade help keep the view clear and the cab comfortable.

Convenient 12-volt port provides power for cell phones and other accessories.

Deluxe suspension seat and wide armrests fully adjust for daylong comfort and support.

Illuminated gauges, warning lights, and audible warnings keep the operator apprised of vital operating information.

Total Machine Control (TMC) allows customized forward/reverse ground-speed ranges, steering modulation, FNR shift rate, decelerator/brake modulation, and forward/reverse speed ratios for superb, one-of-a-kind control.

Need to extend your workday? ROPS cab- or canopy-mounted halogen work lights come standard, for superior illumination.

Decelerator/brake gives low-effort toe-tip control of ground speed for close-quarters finesse.

**1.** Operators won't have to feel their way on this loader. A large expanse of tinted glass provides a panoramic view of the work at hand.



**2.** There's plenty of space inside for a cooler and other carryons, plus two ground-level-accessible lockable storage compartments for chains, tools, or whatever.



**3.** Pilot-controlled open-center load-sensing hydraulics deliver smooth, low-effort combined-function metering and control. Return-to-dig, float, and boom-height kick-out all come standard, for quicker cycles.

**4.** Choose either joystick FNR or V-pattern FNR and pedals. Both provide intuitive, low-effort control of steering, forward/reverse travel, and ground speed.



Steeply sloped track frame covers shed dirt easily and simplify cleanout. So it's more likely to get done.

Heavy-duty rear bumper protects the cooling system and serves as a counterweight for improved stability.

Loader hoses are durable and easily fabricated, so they're readily available should you ever need a replacement. O-ring face-seal couplers virtually eliminate leaks.

One-piece mainframe resists torsional stress, absorbs shock loads, and delivers maximum strength while allowing easy service access to major components.

Wet-sleeve cylinder liners provide uniform engine cooling and longer durability than cast-in-block designs.

Sealed transmission electrical connectors with gold-plated pins prevent moisture and contaminants from short-circuiting productivity.

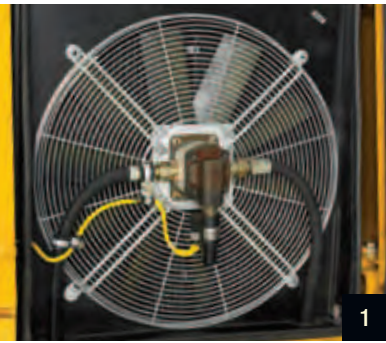

1. Variable-speed hydraulic-driven fan runs only as fast as necessary, reducing debris intake, noise, and fuel consumption. Suction fan is more efficient than blower designs, eliminating the need for screens or oversize coolers.



2. Heavy-duty final drives are mounted within the track pads to protect them from damage. Ground clearance is best-in-class.



3. Dura-Trax™ heavy-duty sealed undercarriage is loaded with features that give it uncommon value and durability. Links and rollers are hardened through the wear limit for long and consistent life; idlers and carrier rollers are lifetime lubricated.



4. Tilting operator station provides wide-open access to drivetrain components. No need to disconnect linkages, hydraulics, or wiring, so it takes only minutes.



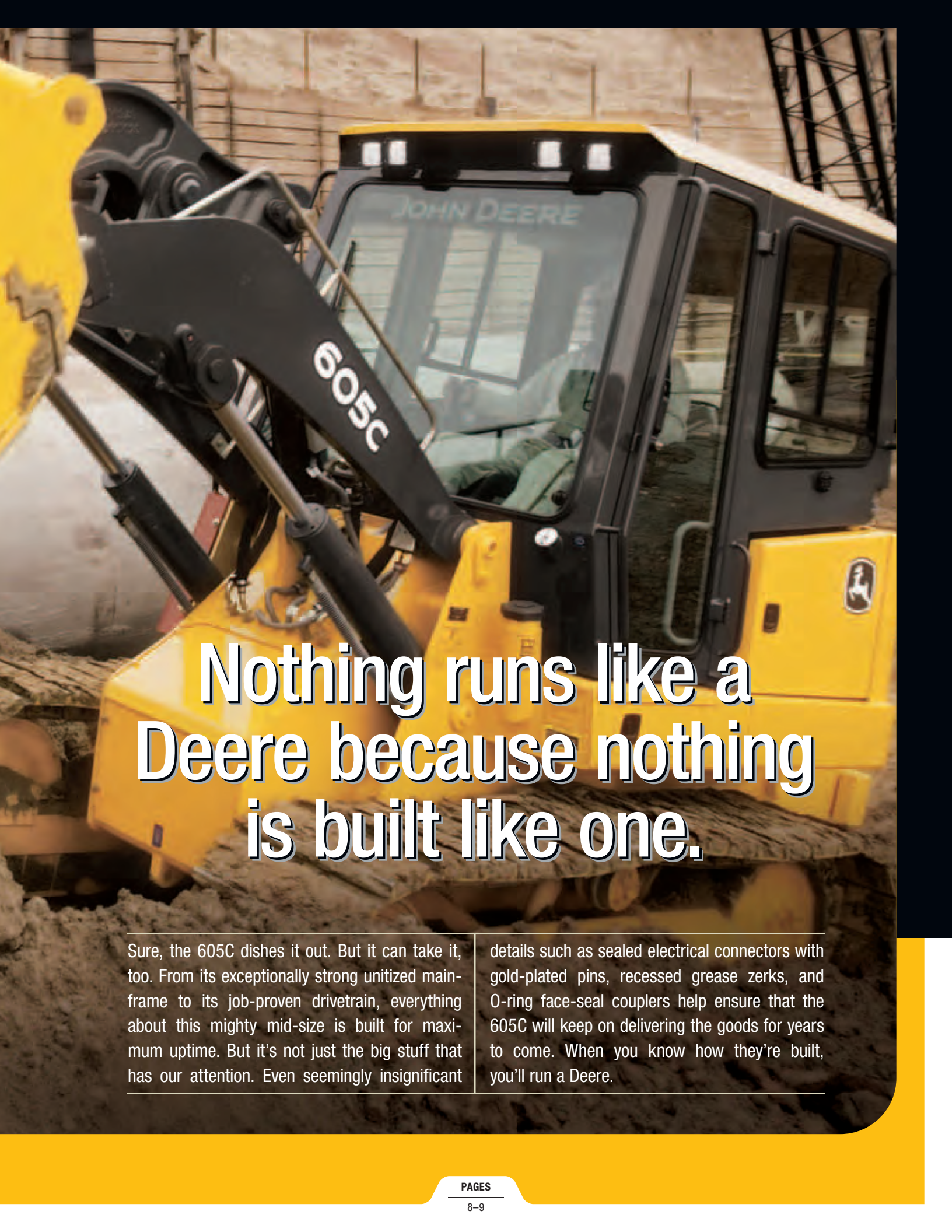

# Nothing runs like a Deere because nothing is built like one.

Sure, the 605C dishes it out. But it can take it, too. From its exceptionally strong unitized main-frame to its job-proven drivetrain, everything about this mighty mid-size is built for maximum uptime. But it's not just the big stuff that has our attention. Even seemingly insignificant

details such as sealed electrical connectors with gold-plated pins, recessed grease zerks, and O-ring face-seal couplers help ensure that the 605C will keep on delivering the goods for years to come. When you know how they're built, you'll run a Deere.

Lockable doors provide wide-open ground-level access to sight gauges, dipsticks, vertical spin-on filters, maintenance-free batteries, fill tubes, and engine, transmission, and hydraulic filters.

Wide radiator and cooler fin spacing lets trash easily pass through cores to resist plugging. For more efficient cooling and easy cleanout.

Serpentine belt never needs adjusting. 500-hour engine oil and 2,000-hour transmission and hydraulic oil service intervals let you go longer between changes. And decrease expense.

Hydrostatic and hydraulic systems employ case-drain filters, eliminating any possibility of cross contamination.

If something goes wrong, the advanced monitor provides diagnostic messaging to help get you back up and running quickly.



# Uncover new ways to keep operating costs down.

On the surface, the resemblance between the 605C Loader and its highly popular J-Series Dozer siblings isn't obvious. But swing open the side shields and you'll discover many of the same time- and money-saving features. Left-side ground-level service points make

quick work of the daily routine. And simplified periodic maintenance and extended engine and hydraulic service intervals let you work longer between changes. If you're looking for a way to reduce daily operating costs and simplify maintenance, you'll find it in the 605C.

1. Sight gauges are conveniently located and easy to read for quick engine coolant and hydraulic/hydrostatic fluid-level checks.

2. Vertical spin-on filters allow quick, no-spill changes. Engine, hydraulics, and transmission utilize a common oil, further simplifying service.

3. Bucket pins are sealed and lubricated for virtually maintenance-free service and long life. Grease zerks are recessed or protected where vulnerable.

4. Remote drive-system test ports and diagnostic messaging enable technicians to quickly troubleshoot problems.

5. Forty-eight-gallon fuel tank lets you work longer between fill-ups. Wide-mouth fill tube allows quick ground-level refueling.

6. Convenient lubrication and maintenance chart serves as a handy reference, helping ensure that nothing gets overlooked.



# Specifications

## Engine

### 605C

Type	John Deere 4045T water-cooled and turbocharged diesel; certified to EPA Tier 2 emissions
Rated Power	99 SAE net hp (74 kW) @ 2,200 rpm per ISO 9249
Cylinders (wet sleeve)	4
Displacement	276 cu. in. (4.5 L)
Fuel Consumption, Typical	1.9 to 3.0 gal./hr. (7.2 to 11.9 L/h)
Maximum Net Torque	307 lb.-ft. (394 Nm) @ 1,400 rpm
Lubrication	pressure system with full-flow spin-on filter and integrated oil-to-water cooler
Air Cleaner	dual stage dry type with safety element and pre-cleaner, with dash-mounted restriction indicator
Electrical System	24 volt with 45-amp alternator
Cooling Fan	suction type, hydrostatic drive
Cold-Starting Aid	intake air heater

## Transmission

Dual-path, electronic-controlled, closed-loop hydrostatic drive; power-management feature automatically adjusts speed and power to match changing load conditions; each individual track is powered by a variable displacement pump and motor combination; single joystick lever controls speed and direction; ground speed (forward and reverse) infinitely variable; modulated center-mounted brake pedal; two working ranges; maximum speed-range control button located on left console; maximum speed in range is selected by F-N-R lever position

Travel Speeds (infinitely variable)

Forward and Reverse Speed Ranges

Low Speed Range . . . . . 0 to 3.3 mph (0 to 5.3 km/h)

High Speed Range . . . . . 0 to 5.5 mph (0 to 8.9 km/h)

## Final Drives

Heavy-duty triple-reduction final drives attach directly to the mainframe

## Steering

Fully modulated, infinitely variable steering provides full power turns and counterrotation with unlimited maneuverability and optimum control; two steering options are available: single-lever joystick steering with infinitely variable speed OR infinitely variable-speed V-pattern with pedal steering

## Brakes

Hydrostatic (dynamic) braking stops the machine whenever the direction-control lever is moved to neutral or whenever the fully modulated brake pedal is fully depressed

## Automatic Park Brake

Exclusive park brake feature engages wet, multiple-disc brakes whenever the engine stops, whenever the combined decelerator/brake pedal is fully depressed, whenever the park lock lever is placed in the start position, whenever the park brake button is pushed on the right console, whenever the F-N-R control is in the neutral position for more than seven seconds, or whenever machine motion is sensed with F-N-R in neutral position; machine cannot be driven with brake applied, reducing wear out or need for adjustment

## Hydraulic System

System	open-center, pilot-operated control valve
Pressure, System Relief	3,335 psi (23 000 kPa)
Pump Type	fixed displacement gear pump
Flow	30.4 gpm (115 L/min.) @ 2,200 rpm
Filter, Return Oil	10 micron with magnetic particle attractors
Control	single joystick lever with optional multipurpose bucket-control toggle mounted in single-lever grip

**Hydraulic System (continued)****605C**

---

Cylinders . . . . .	heat-treated, chrome-plated, polished cylinder rods with hardened steel pivot pins and replaceable bushings
Hydraulic/Transmission Cooling . . . . .	oil-to-air heater exchanger
Loader Cycle Times	
Lifting . . . . .	6.4 sec.
Lowering . . . . .	3.1 sec.
Bucket Dump . . . . .	1.9 sec.

**Refill Capacities (U.S.)**

---

Fuel Tank with Lockable Cap. . . . .	48 gal. (180 L)
Cooling System with Recovery Tank . . . . .	6.3 gal. (24 L)
Engine Oil Including Spin-On Filter . . . . .	3.9 gal. (14.7 L)
Hydraulic/Hydrostatic Reservoir with Filter . . . . .	33.3 gal. (126 L)
Splitter Drive . . . . .	1.85 qt. (1.75 L)
Final Drive (each) . . . . .	9.25 qt. (8.75 L)

**Undercarriage**

---

John Deere Dura-Trax™ features large deep-heat-treated components; pins and bushings are sealed for life; rollers and idlers are permanently sealed and lubricated; full-length track frame covers reduce material buildup and ease cleaning	
Chain . . . . .	sealed and lubricated
Track Shoes (each side) . . . . .	38
Ground Contact Area	
18-in. (457 mm) Grouser Width (closed center, double bar) . . . . .	3,130 sq. in. (20 199 cm <sup>2</sup> )
20-in. (508 mm) Grouser Width (closed center, double bar) . . . . .	3,480 sq. in. (22 454 cm <sup>2</sup> )
Ground Clearance, Minimum with Double-Bar Grouser (excluding grouser height) . . . . .	
Length of Track on Ground . . . . .	87 in. (2210 mm)
Track Gauge (standard) . . . . .	63 in. (1600 mm)
Track Rollers (each side) . . . . .	6
Carrier Rollers (each side) . . . . .	1
Track Pitch . . . . .	6.73 in. (171 mm)

**Ground Pressures**

---

With Standard Equipment, Canopy, Bucket, Full Fuel Tank, and 175-lb. (79 kg) Operator	
Standard Bucket with Bolt-On Teeth	
With 18-in. (457 mm) Double-Grouser Shoes . . . . .	7.5 psi (52 kPa)
With 20-in. (508 mm) Double-Grouser Shoes . . . . .	6.8 psi (47 kPa)
Multipurpose Bucket with Bolt-On Teeth	
With 18-in. (457 mm) Double-Grouser Shoes . . . . .	7.8 psi (54 kPa)
With 20-in. (508 mm) Double-Grouser Shoes . . . . .	7.1 psi (49 kPa)

**SAE Operating Weight**

---

With Standard Equipment, Canopy, Standard Bucket, Full Fuel Tank, 175-lb. (79 kg) Operator, and 18-in. (457 mm) Double-Grouser Shoes . . . . .	
	23,600 lb. (10 700 kg)

## Optional or Special Equipment

605C

Add (+) or deduct (-) lb. (kg) as indicated to base weight for units with

18-in. (457 mm) Track Shoes . . . . .	included in base unit
20-in. (508 mm) Track Shoes . . . . .	194 lb. (88 kg)
Additional Front Lights (2) (cab only) . . . . .	26 lb. (12 kg)
Bolt-On Rock Guards . . . . .	260 lb. (118 kg)
Cab with Air Conditioning . . . . .	1,358 lb. (616 kg)
Heavy-Duty Rear Bumper* . . . . .	476 lb. (216 kg)
Hydraulic Controls for Front Attachment . . . . .	included with multipurpose bucket
Multipurpose Bucket with Bolt-On Teeth . . . . .	794 lb. (360 kg)
Rear Counterweight† . . . . .	230 lb. (106 kg)
ROPS Canopy (less cab) . . . . .	included in base unit
Segmented Cutting Edges . . . . .	176 lb. (80 kg)

\*Included in base unit. / †Included in canopy base unit.

## Dimensions

Rounded to the nearest whole number.

<b>A</b> Height over Canopy (including grousers) . . .	118 in. (2998 mm)
<b>B</b> Height over Exhaust Pipe . . . . .	90 in. (2276 mm)
<b>C</b> Length to Front of Track . . . . .	152 in. (3859 mm)
<b>D</b> Overall Length (with standard bucket with bolt-on teeth) . . . . .	212 in. (5383 mm)
<b>E</b> Track Gauge . . . . .	63 in. (1600 mm)
<b>F</b> Ground Clearance . . . . .	16 in. (408 mm)

## Standard Bucket with Bolt-on Teeth and Segmented Cutting Edges

Capacity Heaped . . . . .	1.7 cu. yd. (1.3 m <sup>3</sup> )
Breakout Force . . . . .	22,480 lb. (10 200 kg)
Static Tipping Load . . . . .	14,750 lb. (6690 kg)
<b>G</b> Dumping Height at 45 Degrees . . . . .	105 in. (2679 mm)
<b>H</b> Reach at 45 Degrees . . . . .	35 in. (890 mm)
<b>I</b> Maximum Digging Depth Below Grade . . . . .	5.1 in. (130 mm)
<b>J</b> Maximum Operating Height . . . . .	176 in. (4474 mm)
<b>K</b> Maximum Height of Hinge Pin . . . . .	133 in. (3368 mm)
<b>L</b> Height of Hinge Pin, Transport Position . . . . .	18.1 in. (459 mm)
<b>M</b> Width of Bucket . . . . .	91 in. (2300 mm)

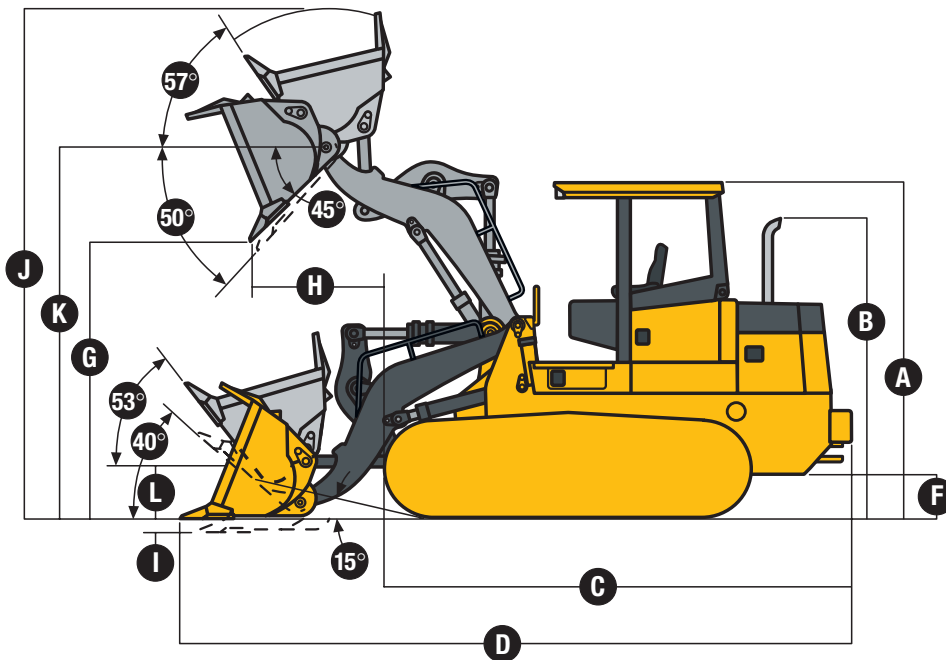

**605C CRAWLER LOADER  
WITH ROPS CANOPY  
AND STANDARD BUCKET**

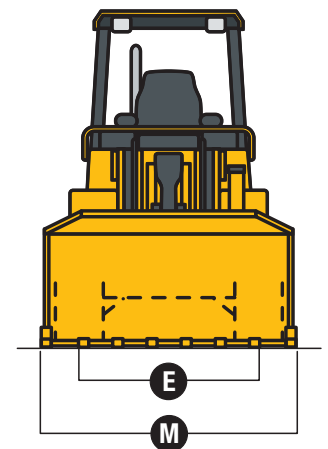

**Multipurpose Bucket with Bolt-on  
Teeth and Segmented Edges**

**605C**

Capacity Heaped . . . . .	1.7 cu. yd. (1.3 m <sup>3</sup> )
Breakout Force . . . . .	21,356 lb. (9687 kg)
Static Tipping Load . . . . .	13,950 lb. (6328 kg)
Maximum Clamping Force . . . . .	13,040 lb. (5914 kg)
<b>D</b> Overall Length (with multipurpose bucket with bolt-on teeth) . . . . .	214 in. (5425 mm)
<b>G</b> Dumping Height at 45 Degrees – Bucket . . .	104 in. (2647 mm)
<b>G'</b> Dumping Height at 45 Degrees – Blade . . .	119 in. (3017 mm)
<b>H</b> Reach at 45 Degrees – Bucket . . . . .	36 in. (908 mm)
<b>H'</b> Reach at 45 Degrees – Blade . . . . .	21.3 in. (542 mm)
<b>I</b> Maximum Digging Depth Below Grade . . . .	5.5 in. (140 mm)
<b>J</b> Maximum Operating Height – Bucket Open . . . . .	198 in. (5024 mm)
<b>J'</b> Maximum Operating Height – Bucket Closed . . . . .	178 in. (4519 mm)
<b>K</b> Maximum Height of Hinge Pin . . . . .	133 in. (3368 mm)
<b>L</b> Height of Hinge Pin, Transport Position . . . .	18.1 in. (459 mm)
<b>M</b> Width of Bucket . . . . .	90.6 in. (2300 mm)
<b>N</b> Width of Opening . . . . .	43.1 in. (1095 mm)

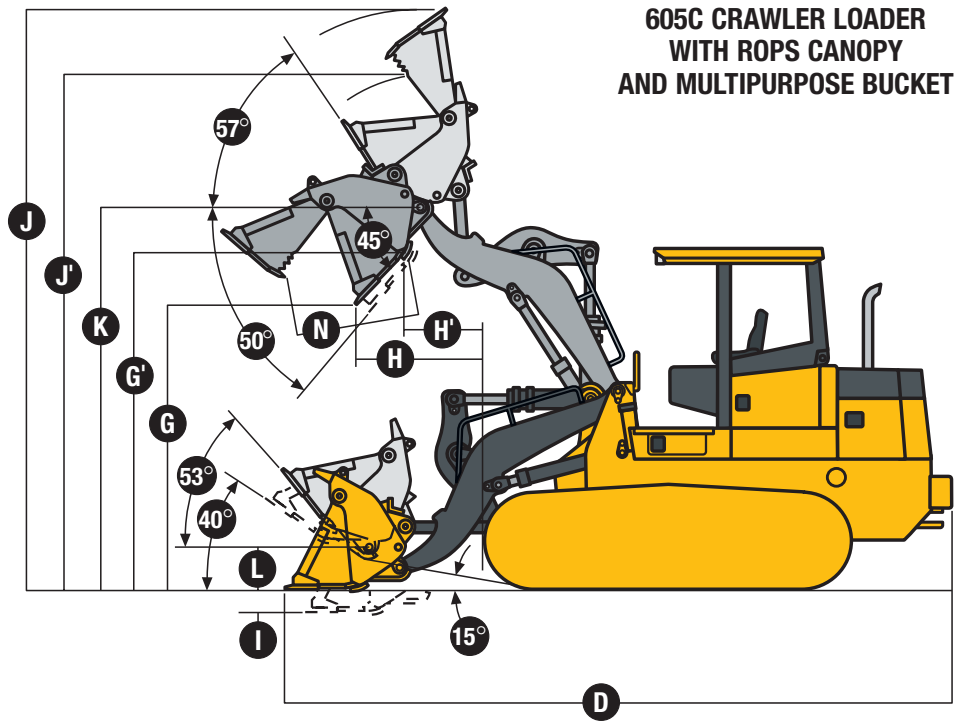

**605C CRAWLER LOADER  
WITH ROPS CANOPY  
AND MULTIPURPOSE BUCKET**

## 605C CRAWLER LOADER

**Key:** ● Standard equipment ▲ Optional or special equipment

\*See your John Deere dealer for further information.

### 605C Engine

- Certified to EPA Tier 2 emissions
- John Deere 4045T water-cooled and turbocharged diesel
- 99 SAE net hp (74 kW) @ 2,200 rpm per ISO 9249
- Turbocharger provides spark arresting
- Quiet rear-ejecting suction-type hydrostatic cooling fan
- Enclosed fan guard (conforms to SAE J1308)
- Dual-element dry-type aspirated air cleaner with automatic dust ejector
- Engine coolant to -34°F (-37°C)
- Belt-driven water pump
- Fuel system with prefilter and water separator
- Heavy-duty 5-fin-per-in. radiator
- Oil-to-water engine oil cooler
- Pressure lubrication for operation to 45 degrees
- Spin-on full-flow oil filter, with anti-drain back
- Cold-starting aid
- Under-hood muffler with vertical exhaust stack

### Powertrain

- Dual-path hydrostatic transmission: Dynamic braking / Power management and AutoTrac / Infinitely variable steering options: Joystick with infinitely variable speed and direction or pedal steering with V-pattern infinitely variable speed and direction
- Automatic spring-applied, hydraulic-released parking brake
- Park brake switch to neutralize transmission and apply brake
- Pedal-operated secondary service brake
- Oil-to-air cooler for transmission
- Transmission system diagnostic test ports
- Two-speed maximum transmission speed control with indicator in console

### Hydraulic System

- Single joystick control lever
- Pilot-operated open-center system
- Boom float with indicator light
- Fixed-displacement gear pump
- Circuit-protection relief valves
- System diagnostic test ports
- O-ring seal connectors
- Return-oil filtration with magnetic particle extractors
- ▲ Multipurpose bucket hydraulics and control

### 605C Hydraulic System (continued)

- Return-to-dig feature
- Bucket-level indicator
- Loader boom service lock

### Electrical

- 24-volt system
- Alternator, 45 amp
- Batteries, heavy-duty cold start, 760 CCA
- Battery positive terminal covers
- Electrically activated battery master disconnect
- Fuse-protected circuits
- Halogen work lights, front (2) and rear canopy mounted (1)
- ▲ Additional halogen front lights (2)

### Undercarriage

- 61-in. (1600 mm) track gauge
- Front track guides
- Hydraulic track adjusters with hinged covers
- Full-length smooth-surface track frame covers
- Sealed and lubricated track chains
- Bolt-on sprockets
- ▲ Full-length bolt-on rock guards
- Maintenance-free sealed and lubricated idlers and double-flange bottom rollers (6)
- ▲ Double-grouser closed-center track shoe options: 18 in. (457 mm) or 20 in. (508 mm)

### Operator's Station

- Convenient right or left access
- Ergonomically placed slip-resistant steps and handholds
- Hydraulically tilted
- Isolation mounted
- Instrument console with audible and visual warnings for 6 functions: Park brake / Hydrostatic transmission pressure / Engine air filter restriction / Hydraulic/transmission filter restriction / Low alternator voltage
- Gauges, electric, illuminated: Engine oil pressure / Engine oil temperature / Engine coolant temperature / Fuel / Hour meter
- Horn, electric
- Key start switch with electric fuel shutoff
- 12-volt power port
- Engine throttle control, rotary dial

### 605C Operator's Station (continued)

- Deluxe mechanical suspension seat: Adjustable armrests, backrest, height/weight, and fore-aft / Seat-cushion tilt
- Seat belt, 2-in. (50 mm), retractable (conforms to SAE J386)
- Interior-mounted rearview mirror
- Built-in operator's manual storage compartment and operator's manual
- Rubber floor mat
- Modular ROPS/FOPS canopy (conforms to SAE J1040, ISO 3471/3449): Vinyl seat
- ▲ Modular cab with integrated ROPS/FOPS (conforms to SAE J1040, ISO 3471/3449): Deluxe air-suspension power-adjustable seat / Adjustable armrests, backrest, height/weight, and fore-aft / Fabric seat cushions / Seat-cushion tilt / Air conditioner/heater/defroster/pressurizer with filtered fresh-air intake and two-speed fan / Ashtray / Dome light / Lockable doors (open and closed position) / Pull-down sunshade / Provisions for radio installation / Rearview mirror / Sliding side windows / Tinted glass / Windshield wipers, front and rear, with washers
- ▲ Radio AM/FM

### Attachments

- ▲ Large-capacity general-purpose bucket with teeth and segments
- ▲ Large-capacity multipurpose bucket with teeth and segments

### Overall Vehicle

- Hinged reinforced radiator guard
- Vandal protection locks: Battery compartment / Engine access doors / Fuel tank / Hydraulic and transmission access doors / Canopy instrument panel cover
- Heavy-duty one-piece unitized mainframe
- Heavy-duty rear bumper/counterweight
- Rear retrieval hitch with pin
- Reinforced bottom guards
- Reverse warning alarm (conforms to SAE J994, J1446)
- Tool kit with brake-release towing kit
- Z-bar linkage
- Large storage compartments (2)
- ▲ Lifting lugs\*

## CONTROL OWNING AND OPERATING COSTS

Customer Personal Service (CPS) is part of John Deere's proactive, fix-before-fail strategy on machine maintenance that will help control costs, increase profits, and reduce stress. Included in this comprehensive lineup of ongoing programs and services are:

**Fluid analysis program**—tells you what's going on inside *all* of your machine's major components so you'll know if there's a problem *before* you see a decline in performance. Fluid analysis is included in most extended coverage and preventive-maintenance agreements.

**Component life-cycle data**—gives you vital information on the projected life span of components and lets you make informed decisions on machine maintenance by telling you approximately how many hours of use you can expect from an engine, transmission, or hydraulic pump. This information can be used to preempt catastrophic downtime by servicing major components at about 80 percent of their life cycle.

**Preventive Maintenance (PM) agreements**—give you a fixed cost for maintaining a machine for a given period of time. They also help you avoid downtime by ensuring that critical

maintenance work gets done right and on schedule. On-site preventive maintenance service performed where and when you need it helps protect you from the expense of catastrophic failures and lets you avoid waste-disposal hassles.

**Extended coverage**—gives you a fixed cost for machine repairs for a given period of time so you can effectively manage costs. Whether you work in a severe-service setting or just want to spread the risk of doing business, this is a great way to custom-fit coverage for your operation. And an extended coverage contract also travels well because it's backed by John Deere and is honored by *all* Deere construction dealers.

**Customer Support Advisors (CSAs)**—Deere believes the CSA program lends a *personal* quality to Customer Personal Service (CPS). Certified CSAs have the knowledge and skills for helping make important decisions on machine maintenance and repair. Their mission is to help you implement a plan that's right for *your* business and take the burden of machine maintenance off your shoulders.



JOHN DEERE

DKA605C Litho in U.S.A. (06-06)

Net engine power is with standard equipment including air cleaner, exhaust system, alternator, and cooling fan, at standard conditions per SAE J1349 and DIN 6270B, using No. 2-D fuel at 35 API gravity. No derating is required up to 10,000-ft. (3050 m) altitude. Gross power is without cooling fan.

Specifications and design subject to change without notice. Wherever applicable, specifications are in accordance with SAE standards. Except where otherwise noted, these specifications are based on a unit with standard equipment, 20-in. (508 mm) track grouser shoes, 2.35-cu.-yd. (1.8 m<sup>3</sup>) bucket, modular cab with air conditioning, full fuel tanks, and 175-lb. (79 kg) operator.

