

Tandem Vibratory Roller

BW900-2



EARTHWORKS

# passes	rolling speed (mph)	area coverage sq yd/hr	"productivity in cu yd/hr by lift thickness, 100% efficiency"			
			4 inches	6 inches	8 inches	12 inches
2	2.5	2163	241	361	481	602
3	2.5	1442	160	241	321	401
4	2.5	1082	120	181	241	301
5	2.5	865	96	144	193	241

ASPHALTIC CONCRETE (material weight 140 lb/cu ft)

# passes	rolling speed (mph)	area coverage sq yd/hr	"productivity in tons/hr by lift thickness, 100% efficiency"			
			1.5 inches	2 inches	2.5 inches	3 inches
2	2.5	2163	171	227	284	341
3	2.5	1442	114	152	190	227
4	2.5	1082	85	114	142	171
5	2.5	865	68	91	114	136
6	2.5	721	57	76	95	114

Note: Repeat number of passes over the same area is required to achieve specified compaction efficiency/density. Successive passes over same area results in reduced area coverage and productivity. Rolling speed selected provides impact spacing of a minimum 10 impacts per foot at high vibration frequency setting. Actual compaction efficiency is determined by job conditions.

Technical Specifications

BW900-2

High performance at an affordable price

Bomag's newest ride-on, tandem vibratory roller, the BW900-2, offers the features and benefits of our larger rollers in a smaller package. Equipped with a 18 hp Honda engine, this unit provides 3150 lbs centrifugal force to enhance productivity. Features such as the heavy duty articulation joint, Spring-Applied, Hydraulically-Released (SAHR) brake system, vibration isolated engine mounts and much more contribute to its strength and durability. Additionally, the combination of compact size, maneuverability and minimal lateral overhang makes it ideal for working in confined areas. The versatility of the BW900-2 makes it the perfect choice for a wide range of both soil and asphalt compaction applications.

Applications:

- Granular sub-base compaction
- Walk, bicycle and cart paths
- Driveways
- Parking Lots
- Road rehabilitation and patching

Standard Equipment

- Hydrostatic travel and vibration drives
- Travel drive in series
- Bolt-on oscillating/articulation joint
- Hydrostatic articulated steering
- Spring-Applied, Hydraulically-Released (SAHR) parking brakes on both drums
- Vibration control in travel lever
- 2 scrapers per drum
- Plastic water tank
- Gravity sprinkler system
- Hour meter / Fuel level indicator
- Control and warning indicator lights
- Automatic shutdown at low oil level
- Lockable engine cover
- Vandal protected instrument panel
- Transport lifting points front/rear/central
- Emergency stop button
- Corrosion and weather protected ignition switch
- ROPS with seat belt
- Back-up alarm

Optional Equipment

- Headlights front and rear
- Special paint
- Rotary Beacon

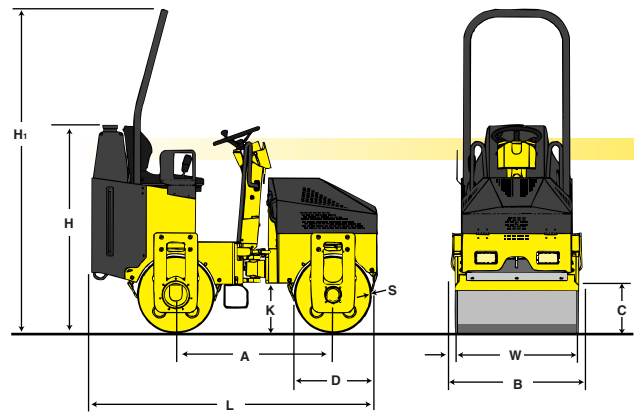

Dimensions in inches (mm)

	A	B	C	D	H	Hi	K	L	O	S	W
BW900-2	45	37.6	18.0	22.0	63.8	92.1	14.3	81.9	1.1	0.32	35.4
	(1143)	(956)	(458)	(560)	(1620)	(2340)	(363)	(2080)	(28)	(8)	(900)

Technical data

Weights

	lbs	(kg)	BOMAG BW900-2	
Basic Weight with ROPS	2497			(1135)
Operating Weight	2924			(1326)
Average axle load.....	1462			(663)
Average static linear load CECE.....	41.31			(7.33)

Dimensions

Length with ROPS	81.9	(2080)
Track Radius, inner.....	63.8	(1620)
Dimensions.....	see sketch	

Driving Characteristics (depending on site conditions)

Speed (with vibration).....	0-2.5	(0-4)
Speed (for transport).....	0-4.4	(0-7.0)
Max. gradeability without/with vibration.....	40/30	

Drive

Engine manufacturer.....	Honda	
Type.....	GX620	
Cooling - cylinders	air	
Number of cylinders	2	
Performance ISO 9249 (max)*.....	20	(14.9)
Speed (max)	3600	
Performance SAE J1349 (max)*.....	20	(14.9)
Speed (max)	3600	
Electric Equipment	12 V	
Drive System.....	hydrostatic	
Drum Driven.....	f + r (Series)	

Brakes

Service brake.....	SAHR
Parking brake.....	hydromechanical

Steering

Steering system	oscillating, articulating
Steering method.....	hydrostatic
Steering angle ±.....	31
Oscillating angle ±	6

Vibratory system

Vibrating drum.....	front	
Drive system	hydrostatic	
Frequency	3900	(65)
Amplitude.....	0.020	(0.5)
Centrifugal force (front drum).....	3150	(14)

Water Spray System

Type of water spray system.....	gravity
---------------------------------	---------

Capacities

Fuel.....	9	(34)
Water	50	(189)

Technical modifications reserved. Machines may be shown with options.

* Actual machine horsepower setting is 18 hp (13.2 kW) at 3,000 rpm.

B186GH-2084 2M208TTTT



BOMAG Americas, Inc.

2000 Kentville Rd. • Kewanee, IL 61443
Tel: 309 853-3571 • Fax: 309 852-0350