

## Combination Vibratory Roller

### BW120AC-4



ASPHALTIC CONCRETE (material weight 140 lb/cu ft)						
# passes	rolling speed (mph)	area coverage sq yd/hr	"productivity in tons/hr by lift thickness, 100% efficiency"			
			1.5 inches	2 inches	2.5 inches	3 inches
2	4.77	2752	217	289	362	434
3	4.77	1835	145	193	241	289
4	4.77	1376	109	145	181	217
5	4.77	1101	87	116	145	174
6	4.77	917	72	96	121	145

Note: Repeat number of passes over the same area is required to achieve specified compaction efficiency/density. Successive passes over same area results in reduced area coverage and productivity. Rolling speed selected provides impact spacing of a minimum 10 impacts per foot at high vibration frequency setting. Actual compaction efficiency is determined by job conditions.

# Technical Specifications

## BW120AC-4

### Shipping dimensions

in cubic feet (m<sup>3</sup>)

without/with ROPS

BW120AC-4 200.8 (5.69) 277.7 (7.86)

### Standard Equipment

- Oscillating articulating center joint
- Suspended operator's platform
- Plastic water tank
- Hour meter
- Lockable engine cover
- Lockable anti-vandal dashboard protection
- Transport lashing and lifting points front/rear
- Emergency stop button
- Back-up alarm
- Water level
- Fuel level indicator
- Pressurized water sprinkler system
- Laterally sliding seat
- FOPS/ROPS with safety belts

### Optional Equipment

- Working lights front/rear
- Crab walk (1.6 in / 40 mm)
- Seat with contact switch
- Edge cutter
- Indicator and hazard lights
- Rotary beacon
- Biodegradable hydraulic oil
- Special paint
- Tool kit
- Double travel lever (Sliding Seat)
- Foldable ROPS with seat belts
- ROPS with seat belts
- Single point lifting device

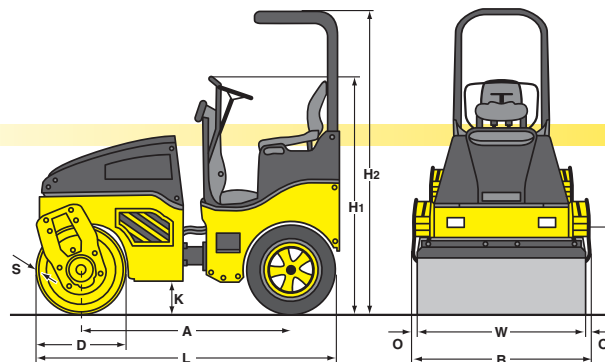

### Dimensions in inches (mm)

	A	B	C	D	H <sub>1</sub>	H <sub>2</sub>	K	L	O	S	W
BW120AC-4	69.5 (1765)	50.23 (1276)	21.9 (555)	27.6 (700)	70.9 (1800)	98.0 (2490)	8.3 (210)	97.4 (2475)	1.5 (38)	0.5 (13)	47.2 (1200)

### Technical data

#### Weights

Basic Weight with ROPS	lbs (kg)	4747 (2153)
Operating Weight	lbs (kg)	5247 (2380)
Average axle load (Drum)	lbs (kg)	2733.7 (1240)
Average axle load (Wheels)	lbs (kg)	2513.7 (1140)
Static linear load CECE	pli (kg/cm)	57.9 (10.3)
Wheel load CECE	lbs (kg)	628.3 (285)

#### Dimensions

Track Radius, inner	in (mm)	103.1 (2620)
Dimensions		see sketch

#### Driving Characteristics (depending on site conditions)

Speed (with vibration)	mph (kmph)	0-3.72 (0-6)
Speed (for transport)	mph (kmph)	0-6.2 (0-10)
Max. gradeability without/with vibration	%	40/30

#### Drive

Engine manufacturer		Kubota
Type		D 1703 MDI
Cooling		Water
Number of cylinders		3
Performance ISO 9249 (max)	hp (kW)	34.3 (25.2)
Speed (max)	rpm	2700
Performance SAE J1349 (max)	hp (kW)	33.8 (25.2)
Speed (max)	rpm	2700
Throttle position 1	rpm	2200
Throttle position 2	rpm	2600
Electric Equipment	V	12

#### Brakes

Service brake	hydrostatic
Parking brake	SAHR

#### Steering

Steering system	oscillating, articulating
Steering method	hydrostatic
Steering angle +/-	30 degrees
Oscillating angle +/-	12 degrees

#### Vibratory system

Drive system		hydrostatic
Frequency	vpm (Hz)	3300/4020 (55/67)
Amplitude	in (mm)	0.020 (0.52)
Centrifugal force (each drum)	lbs (kN)	8325/10125 (37/45)

#### Capacities

Fuel	gal (l)	10.6 (40)
Water	gal (l)	58.1 (220)
Emulsion	gal (l)	5.3 (20)

Technical modifications reserved. Machines may be shown with options.