

Tandem Vibratory Roller

BW100AD-4



EARTHWORKS						
# passes	rolling speed	area coverage sq yd/hr	"productivity in cu yd/hr by lift thickness, 100% efficiency"			
	(mph)		4 inches	6 inches	8 inches	12 inches
2	4.77	4594	511	767	1022	1534
3	4.77	3063	341	511	682	1022
4	4.77	2297	256	387	511	767
5	4.77	1838	204	307	409	613

ASPHALTIC CONCRETE (material weight 140 lb/cu ft)						
# passes	rolling speed	area coverage sq yd/hr	"productivity in tons/hr by lift thickness, 100% efficiency"			
	(mph)		1.5 inches	2 inches	2.5 inches	3 inches
2	4.77	4594	362	483	604	725
3	4.77	3063	242	322	403	483
4	4.77	2297	181	242	302	362
5	4.77	1838	145	193	242	290
6	4.77	1531	121	161	201	242

Note: Repeat number of passes over the same area is required to achieve specified compaction efficiency/density. Successive passes over same area results in reduced area coverage and productivity. Rolling speed selected provides impact spacing of a minimum 10 impacts per foot at high vibration frequency setting. Actual compaction efficiency is determined by job conditions.

BW100AD-4

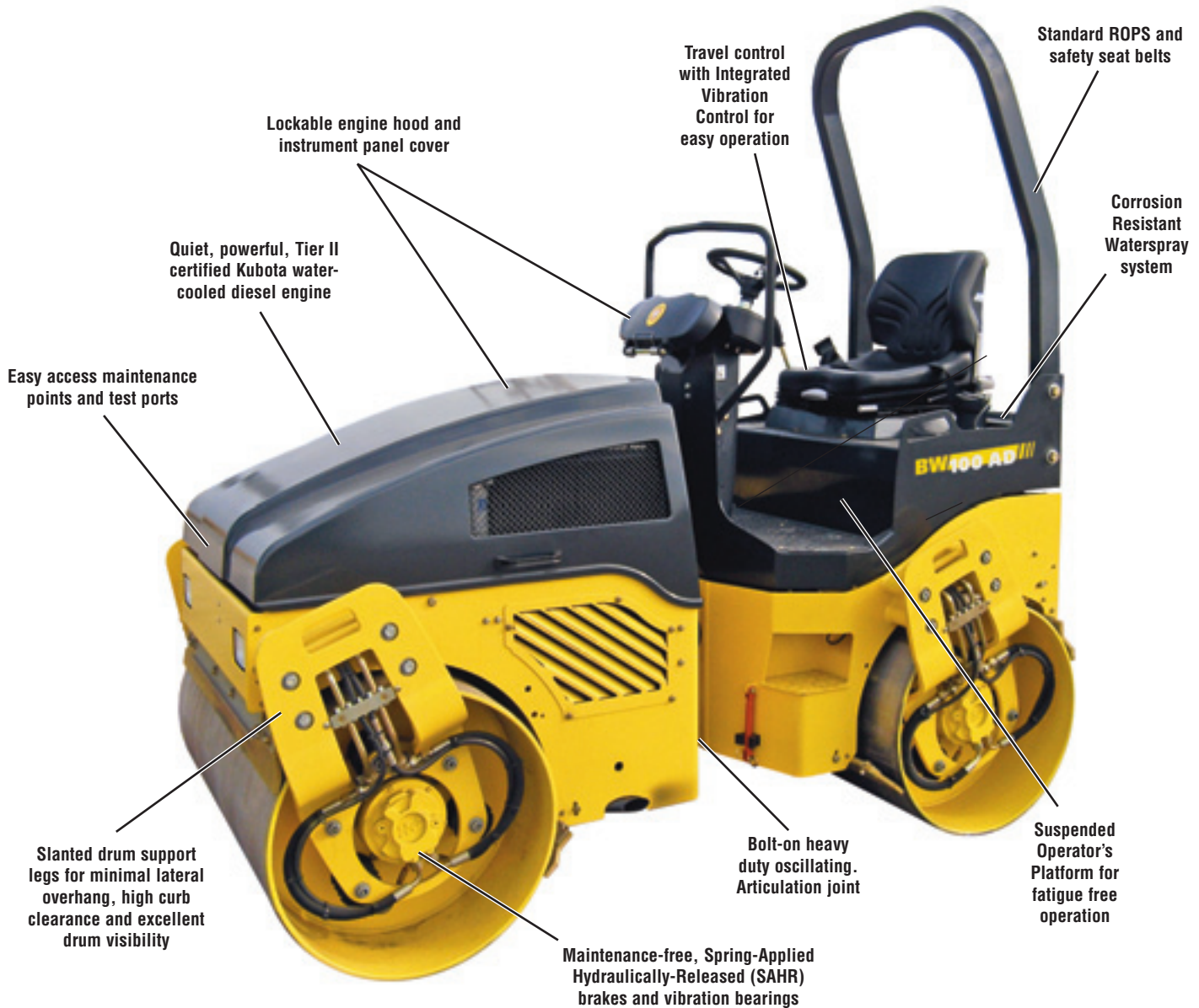

■ Dash 4 Series – Setting the standard for excellence...

Combining heavy tandem roller features and outstanding performance with compact size and high maneuverability, the next generation BW100AD-4 sets a standard for what other competitive rollers should be.

This new model from BOMAG features more performance, increased productivity, improved safety details and unsurpassed operator comfort. Slanted drum support legs with high curb clearance, afford unobstructed view of the drum edges, minimal lateral offset and the ability to work closely to obstructions and in confined areas.

The two (2) position throttle detail offers dual vibration frequencies, providing maximum compaction results on a wide range of applications and material types.

■ Applications:

- Granular sub-base compaction
- Walkways, bicycle and cart paths
- Driveways
- Parking lots
- Road rehabilitation and patching



BW100AD-4 rolling a curbline.

Featuring...



Ergonomically engineered operator's platform providing optimum comfort and maximum productivity.

Light duty tandem models provide maximum versatility and productivity

Achieve Maximum Productivity:

- The BW100AD-4 has two (2) vibration frequencies for optimized compaction on a wider range of material types.
- Vibration can be selectively shut-off on the rear drum to prevent over compaction and material damage to sensitive material types and thin lift applications.
- Large diameter drums minimize pushing and cracking of mat surface, delivering a high quality finish.
- High curb clearance and minimal lateral overhang allow for working close to obstructions.
- Standard dual drum scrapers (2 per drum) ensure clean drums in either forward or reverse travel direction.
- Drum amplitude and frequency are optimized to provide high performance and maximum productivity on a wide range of applications.
- Water spray system automatically cancels in neutral travel position, extending tank life.

Less Service & Maintenance:

The purchase price is always important, But more importantly are the operating costs.

Check these features:

- Drum shell wrapper thickness and head plates are designed to provide maximum strength for long life and durability.
- Vandal protected instrument panel detail insures against on-site electrical problems.
- Bolt-on oscillating, articulation joint provides long life and simplifies repairs.
- Wide opening, lockable, composite engine cover provides easy service access and minimizes possible underhood vandalism.
- The BOMAG hydraulic oil filtration system extends servicing intervals to 2000 hours.
- Drum vibration bearings and travel system SAHR brakes are maintenance free.
- Hydraulic test ports are easily accessible for simplified troubleshooting.
- Daily maintenance check points are quickly completed with easy access, visual indicators for hydraulic oil level, oil filter and air filter.
- Water spray pump and filter are easily accessed in a centralized location and sprinkler nozzles are quick disconnect design for easy cleaning when required.



Vibration isolated operators platform minimizes operator fatigue. Standard ROPS with safety seat belts.



Bolt-on center-joint, with standard crab steer off-set, provides long life and ease of repair.



Easy access engine and drive components for simplified servicing

With these features and many more, it's easy to see why this model maintains a high residual value while delivering lower lifetime operating costs.

Technical Specifications

BW100AD-4

Shipping dimensions

in cubic feet (m ³)	without/with ROPS	
BW100AD-4	168.9 (4.8)	233.7 (6.6)

Standard Equipment

- Oscillating articulating center joint
- 2 scrapers per drum
- Suspended operator's platform
- Plastic water tank
- Hour meter
- Lockable engine cover
- Crab walk (1.6 in / 40 mm)
- Lockable anti-vandal dashboard protection
- Transport lashing and lifting points front/rear
- Emergency stop button
- Vibration cut-off, rear drum
- Emergency stop button
- Back-up alarm
- Water level
- Fuel level indicator
- Pressurized water sprinkler system
- Laterally sliding seat
- ROPS with safety belts

Optional Equipment

- Working lights front/rear
- Seat with contact switch
- Edge cutter
- Indicator and hazard lights
- Rotary beacon
- Biodegradable hydraulic oil
- Special paint
- Tool kit
- Double travel lever (Sliding Seat)
- Foldable ROPS
- Single point lifting device

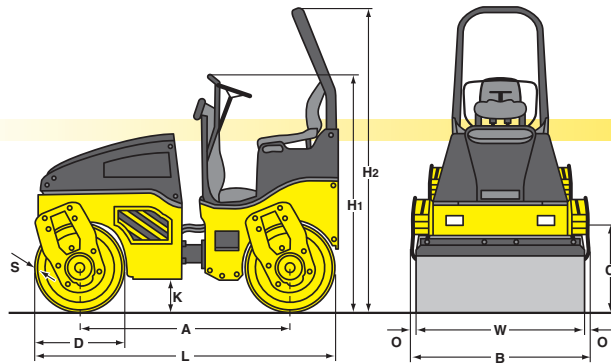

Dimensions in inches (mm)

	A	B	C	D	H	H ₂	K	L	O	S	W
BW100AD-4	68.0	42.4	18.7	27.6	70.9	98.0	9.8	97.2	1.5	0.5	39.4
	(1728)	(1076)	(475)	(700)	(1800)	(2490)	(250)	(2470)	(38)	(13)	(1000)

Technical data

Weights

Basic Weight with ROPS	lbs	(kg)	4807	(2180)
Operating Weight	lbs	(kg)	5291	(2400)
Average axle load	lbs	(kg)	2646	(1200)
Average static linear load CECE	pli	(kg/cm)	67.2	(12.0)

Dimensions

Length with ROPS	in	(mm)	97.2	(2470)
Track Radius, inner	in	(mm)	107.1	(2720)
Dimensions	see sketch			

Driving Characteristics (depending on site conditions)

Speed (with vibration)	mph	(kmph)	0-4.0	(0-6.5)
Speed (for transport)	mph	(kmph)	0-7.5	(0-12)
Max. gradeability without/with vibration			40/30	

Drive

Engine manufacturer	Kubota		
Type	D 1703 MDI		
Cooling	Water		
Number of cylinders	3		
Performance ISO 9249 (max)	hp	(kW)	34.3 (25.2)
Speed (max)	rpm		2600
Performance SAE J1349 (max)	hp	(kW)	33.8 (25.2)
Speed (max)	rpm		2700
Throttle position 1	rpm		2200
Throttle position 2	rpm		2600
Electric Equipment	12 V		

Brakes

Service brake	hydrostatic
Parking brake	SAHR

Steering

Steering system	oscillating, articulating
Steering method	hydrostatic
Steering angle +/-	30 degrees
Oscillating angle +/-	12 degrees

Vibratory system

Vibrating drum	f + r	
Drive system	hydrostatic	
Frequency	vpm (Hz)	3300/4200 (55/70)
Amplitude	in (mm)	0.020 (0.50)
Centrifugal force (each drum)	lbs (kN)	5175/8550 (23/38)

Water Spray System

Type of water spray system	pressurized
----------------------------	-------------

Capacities

Fuel	gal	(l)	10.6	(40)
Water	gal	(l)	58.1	(220)

Technical modifications reserved. Machines may be shown with options.

B395H-1958 4M807TTP