



**JOHN DEERE**

1 6 M E T R I C T O N

**D**

**EXCAVATOR**

160D LC





# Raise your standards.

Your customers expect big things from you, so why shouldn't you expect the same from your mid-size excavator? Delivering the power, smoothness, control, and ease of operation of larger John Deere excavators, the 160D LC exceeds everyone's expectations. Heavier and stronger than before, with strong digging forces,

outstanding lift capability, reach, and swing torque, it produces like a big machine. Operates like one, too, with a spacious, comfortable cab offering generous legroom and unsurpassed visibility. And with an efficient on-demand cooling system and rugged Tier 3 diesel, you can plan on typical Deere uptime and durability, too.



- 160D LC delivers more digging force, swing torque, drawbar pull, and lift capability, with less emissions and noise.
- Extended engine and hydraulic oil-service intervals increase uptime and reduce daily operating costs.
- Spacious operating stations with more legroom and more glass deliver unsurpassed comfort and visibility.
- Powerwise III™ engine/hydraulic management system maximizes power output, saves fuel, and delivers smooth multifunction hydraulic operation.
- Hydraulically driven highly efficient fan runs only as needed, reducing noise, fuel consumption, and operating costs. Reversing option automatically back-blows cooler cores to reduce debris buildup.
- Tier 3 emission-certified John Deere diesels deliver power without compromise in all conditions.

## Specifications 160D LC

Net Power.....	121 hp
Operating Weight .....	39,980 lb.
Lift Capacity .....	9,094 lb.
Digging Depth .....	21 ft. 4 in.
Arm Breakout Force .....	17,243 lb.

160D LC is perfect for “dig-and-run” jobs such as excavating basements. Transports easily between jobsites.

Additional hydraulic capability a necessity? Factory-installed high-pressure, high-flow auxiliary hydraulic packages meet the need.

Choose from a variety of track widths, arm lengths, buckets, and other options and maximize your efforts.

Powerwise III perfectly balances engine performance and hydraulic flow for fast, smooth, and predictable operation. One work mode makes it easy to be productive in any application.



1. For work that requires extra finesse, the 160D LC's best-in-class metering and superb multifunction operation deliver the control you need.

2. When the digging gets tough, simply press the power-boost button for additional hydraulic muscle.

3. Hydraulic recirculation system delivers more efficient flow to the boom and arm, speeding multifunction operation and cycle times.





# Mid-size stature. Big-size results.

With faster hydraulics and significant increases in weight, digging force, swing torque, drawbar pull, and lift capability, you can expect big things from the 160D LC. Its Powerwize III engine/hydraulic management system provides pinpoint metering for smooth, predictable control. And when the digging gets tough, power boost

helps pull you through. But even with all of its extra ability, the 160D LC is still highly maneuverable — working with ease around obstacles and easy to transport between job-sites. Whether you're digging basements, loading trucks, or placing pipe, it may well be all the machine you need.

The image shows the operator's seat and control area of a John Deere 160D LC tractor. The seat is grey fabric. The control panel is black with a multifunction monitor, a gear selector, and various buttons. There are several warning labels on the panel, including 'DANGER', 'WARNING', and 'CAUTION'. The background shows the yellow exterior of the tractor.

# Bring out your operators' best.

With the 160D LC, you get more of everything an operator wants. A wider expanse of tinted glass for virtually unrestricted visibility. Substantially more legroom. Intuitive multifunction monitor. Plus numerous other creature comforts and conveniences including automatic climate control, generous

storage, and available heated air-suspension seat. And yet, for all of its enhancements, the most appreciated amenity may well be the peace and quiet. The sound-suppressed cab and variable-speed fan noticeably reduce fatigue-causing noise. For increased productivity all day long.



Deluxe-suspension multi-position seat has 10½ inches of travel, sliding together or independent of the control console. So it won't cramp an operator's style.

Variable-speed fan, noise-reducing muffler, and isochronous high-idle speed help quiet things down.

Ergonomic short-throw pilot levers provide smooth and predictable low-effort control.

Go from backhoe- to SAE-style controls with just a twist of your wrist. Optional lockable control pattern selector valve comes factory-installed.

No need to leave the seat to match hydraulic flow to your attachment. Changes are push-button easy and done through the monitor.

Convenient 12-volt port powers cell phones and other electronic devices.

Redesigned cab isn't just roomier, it's also noticeably more comfortable. Silicone-filled cab mounts effectively isolate operators from noise and vibration.

1. Forty-seven-percent more glass, narrow front cab posts, large tinted overhead hatch, and numerous mirrors provide virtually unobstructed all-around visibility.

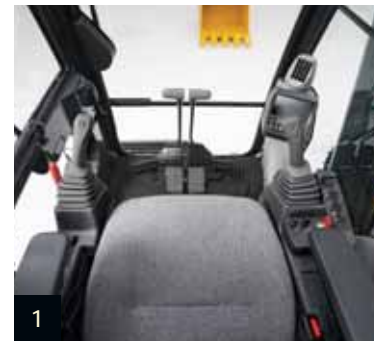

2. No shortage of storage in here. There's a place for a cooler, cup holders, and even a hot/cold box that keeps refreshments at just the right temperature.



3. Automatic, high-velocity bi-level climate-control system with automotive-style adjustable louvers helps keep the glass clear and the cab comfortable.

4. Intuitive, multi-language monitor with four-color LCD screen provides a wealth of info and control. Displays operating, diagnostic, and maintenance data with easy-on-the-eyes clarity.



Optional reversing fan automatically or manually back-blows cooler cores to reduce debris buildup. It's a welcome addition that will increase uptime.

Graphite-iron wet-sleeve cylinder liners, mono-steel pistons, and large-diameter connecting rods ensure long-term engine durability.

Oil-impregnated bushings enhance durability and extend grease intervals to 500 hours (100 hours for the bucket joint). Reinforced resin thrust plates increase boom lube intervals to 500 hours.

Welded bulkheads within the boom resist torsional stress. Boom, arms, and mainframe are so tough, they're warranted for three years or 10,000 hours.

Tungsten-carbide coating creates an extremely wear-resistant surface to protect the all-important bucket-to-arm joint.



1

1. With large idlers, rollers, and struted links, the sealed and lubricated undercarriage delivers long and reliable performance.



2

2. Rigid, reinforced D-channel side frames resist impact, providing maximum cab and component protection.



3

3. Perforations in the hood and side shields serve as a "first filter," preventing trash entry. Anything that passes through will also clear the cooler cores.



4

4. Box-section track frames, thick-plate single-sheet mainframe, and large swing bearing deliver rock-solid durability.





# Nothing runs like a Deere, because nothing is built like one.

Unlike some excavators that scream for attention, the 160D LC's hydraulically driven on-demand fan runs only as needed, reducing noise and fuel consumption. The highly efficient system keeps things running cool, even in high-trash environments and high altitudes.

Other traditional John Deere features include tungsten-carbide thermal-coated arm surfaces, oil-impregnated bushings, and welded-boom bulkheads. For maximum uptime and long-term durability. When you know how they're built, you'll run a Deere.

Machine Information Center (MIC) captures and stores vital machine performance and utilization data to help improve uptime, productivity, and profit.

Auto-idle automatically reduces engine speeds when hydraulics aren't in use, making the most of every precious drop of fuel.

Large, easy-to-open doors provide quick access to service items. Lube banks, filters, and checkpoints are grouped for added convenience.

Large fuel tank and 500- and 5,000-hour engine and hydraulic oil-service intervals enable the 160D LC to work longer between stops for scheduled service.

Fluid-level sight gauges are conveniently located and can be checked at a glance.



# Uncover new ways to keep costs down.

Like all John Deere machines, the 160D LC is loaded with features that make it hassle-free to service and low cost to maintain. Large, easy-to-open service doors and easy-access service points make quick work of the daily routine. Remote-mounted vertical oil and fuel filters and

extended engine and hydraulic oil-change intervals minimize maintenance, too. Plus the Machine Information Center, state-of-the-art LCD color monitor, and fluid-sample ports help you make timely decisions about machine upkeep — and help you manage uptime and costs.

1. Vertical spin-on engine oil and fuel/water filters in the right rear compartment allow ground-level servicing.

2. Easy-to-navigate LCD color monitor tracks up to 14 maintenance intervals and lets an operator check any of 32 machine operating parameters at the touch of a button.

3. Centralized lube banks place difficult-to-lube zerks within easy reach, for faster greasing with less mess.

4. Fresh-air cab filter is quickly serviced from outside the cab where it's more likely to get done.

5. Wide-fin spacing lets trash easily pass through cores to resist plugging. Hinged, swing-out coolers provide additional access.

6. Remote diagnostic and fluid-sample ports help speed preventative maintenance and troubleshooting.



# Specifications

## Engine 160D LC

Manufacturer and Model	John Deere 4045H
Non-Road Emission Standards	certified to EPA Tier 3 emissions
Net Power (ISO9249)	121 hp (90 kW) @ 2,200 rpm
Cylinders	4
Displacement	276 cu. in. (4.5 L)
Aspiration	turbocharged, air-to-air charge air cooler
Off-Level Capacity	100% (45 deg.)

## Cooling

Cool-on-demand hydraulic-driven, suction-type fan with remote-mounted drive

## Powertrain

Maximum Travel Speed	
Low	2.1 mph (3.4 km/h)
High	3.3 mph (5.3 km/h)

## Hydraulics

Open center, load sensing; auxiliary hydraulic flow adjustable through monitor

**Main Pumps** . . . . . 2 variable-displacement axial-piston pumps  
 Maximum Rated Flow . . . . . 2 x 50.4 gpm (2 x 191 L/min.)

**Pilot Pump** . . . . . one gear  
 Maximum Rated Flow . . . . . 8.87 gpm (33.6 L/min.)  
 Pressure Setting . . . . . 570 psi (3930 kPa)

**System Operating Pressure**  
 Implement Circuits . . . . . 4,980 psi (34 336 kPa)  
 Travel Circuits . . . . . 4,980 psi (34 336 kPa)  
 Swing Circuits . . . . . 4,250 psi (29 300 kPa)

**Controls** . . . . . pilot levers, short stroke, low effort; hydraulic pilot controls with shutoff lever

## Cylinders

Heat-treated, chrome-plated, polished cylinder rods; hardened-steel (replaceable bushings) pivot pins

	<i>Bore</i>	<i>Rod Diameter</i>	<i>Stroke</i>
Boom (2)	4.33 in. (110 mm)	3.15 in. (80 mm)	43.70 in. (1110 mm)
Arm (1)	4.72 in. (120 mm)	3.54 in. (90 mm)	53.74 in. (1365 mm)
Bucket (1)	4.13 in. (105 mm)	2.95 in. (75 mm)	36.81 in. (935 mm)

## Electrical

Batteries	2 x 12 volt
Reserve Capacity	180 min.
Alternator	80 amp
Lights	halogen (one mounted on boom, one mounted on frame)

## Undercarriage

Carrier Rollers (per side)	2
Track Rollers (per side)	7
Shoes (per side)	43
Drawbar Pull	38,030 lb. (17 250 kg)
Track	
Adjustment	hydraulic
Chain	sealed and lubricated

## Swing Mechanism

Swing Speed	13.3 rpm
Swing Torque	32,353 lb.-ft. (44 000 Nm)

## Ground Pressure

## 160D LC

Triple Semi-Grouser Shoes	
24 in. (600 mm) . . . . .	6.16 psi (42.5 kPa)
28 in. (700 mm) . . . . .	5.40 psi (37.2 kPa)

## Serviceability

### Refill Capacities

Fuel Tank . . . . .	85 gal. (320.0 L)
Cooling System . . . . .	23 qt. (22.0 L)
Engine Oil with Filter . . . . .	16 qt. (15.0 L)
Hydraulic Tank . . . . .	33 gal. (125.0 L)
Hydraulic System . . . . .	52.0 gal. (196.8 L)
Gearbox	
Propel (each) . . . . .	5.0 qt. (4.7 L)
Swing . . . . .	6.0 qt. (5.7 L)

## Operating Weights

With Full Fuel Tank; 175-lb. (79 kg) Operator;	
36-in. (914 mm), 0.81-cu.-yd. (0.62 m <sup>3</sup> ),	
1,373-lb. (623 kg) Heavy-Duty Bucket; 10-ft.	
2-in. (3.10 m) Arm; 7,275-lb. (3300 kg)	
Counterweight; 12-ft. 10-in. (3.92 m)	
Undercarriage Length; and Triple Semi-	
Grouser Shoes	
24 in. (600 mm) . . . . .	39,508 lb. (17 937 kg)
28 in. (700 mm) . . . . .	39,980 lb. (18 151 kg)

### Optional Components

Undercarriage with Triple Semi-Grouser Shoes	
24 in. (600 mm) . . . . .	13,911 lb. (6316 kg)
28 in. (700 mm) . . . . .	14,383 lb. (6530 kg)
Upperstructure with Full Fuel Tank (less front	
attachments and 7,275-lb. [3300 kg] coun-	
terweight) . . . . .	
One-Piece Boom (with arm cylinder) . . . . .	2,864 lb. (1300 kg)
Arm with Bucket Cylinder and Linkage	
8 ft. 6 in. (2.60 m) . . . . .	1,735 lb. (788 kg)
10 ft. 2 in. (3.10 m) . . . . .	1,925 lb. (874 kg)
Boom Lift Cylinders (2) Total Weight . . . . .	675 lb. (306 kg)
36-in. (914 mm), 0.81-cu.-yd. (0.62 m <sup>3</sup> ) Heavy-	
Duty Bucket . . . . .	1,373 lb. (623 kg)
Counterweight (standard) . . . . .	7,275 lb. (3300 kg)

## Operating Dimensions

	<i>Arm Length</i> 8 ft. 6 in. (2.60 m)	<i>Arm Length</i> 10 ft. 2 in. (3.10 m)
Arm Force with 36-in. (914 mm), 0.81-cu.-yd. (0.62 m <sup>3</sup> ) Heavy-Duty Bucket . . . . .	19,352 lb. (86.1 kN)	17,243 lb. (76.7 kN)
Bucket Digging Force with 36-in. (914 mm), 0.81-cu.-yd. (0.62 m <sup>3</sup> ) Heavy-Duty Bucket . . . . .	22,697 lb. (101.0 kN)	22,697 lb. (101.0 kN)
Lifting Capacity Over Front at Ground Level		
20-ft. (6.1 m) Reach . . . . .	9,105 lb. (4134 kg)	9,094 lb. (4129 kg)
<b>A</b> Maximum Reach . . . . .	29 ft. 1 in. (8.87 m)	30 ft. 7 in. (9.33 m)
<b>A'</b> Maximum Reach at Ground Level . . . . .	28 ft. 7 in. (8.70 m)	30 ft. 1 in. (9.16 m)
<b>B</b> Maximum Digging Depth . . . . .	19 ft. 7 in. (5.98 m)	21 ft. 4 in. (6.49 m)
<b>B'</b> Maximum Digging Depth at 8-ft. (2.44 m) Flat Bottom . . . . .	18 ft. 10 in. (5.74 m)	20 ft. 7 in. (6.27 m)
<b>C</b> Maximum Cutting Height . . . . .	29 ft. 2 in. (8.88 m)	29 ft. 11 in. (9.13 m)
<b>D</b> Maximum Dumping Height . . . . .	20 ft. 3 in. (6.17 m)	21 ft. 0 in. (6.40 m)
<b>E</b> Minimum Swing Radius . . . . .	9 ft. 7 in. (2.91 m)	9 ft. 7 in. (2.92 m)
<b>F</b> Maximum Vertical Wall . . . . .	16 ft. 11 in. (5.16 m)	18 ft. 8 in. (5.69 m)
<b>G</b> Tail Swing Radius . . . . .	8 ft. 2 in. (2.49 m)	8 ft. 2 in. (2.49 m)

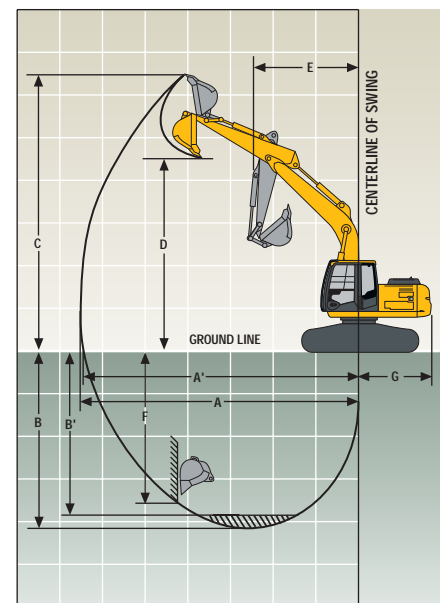

## Machine Dimensions

### 160D LC

	Arm Length 8 ft. 6 in. (2.60 m)	Arm Length 10 ft. 2 in. (3.01 m)
<b>A</b> Overall Length	28 ft. 1 in. (8.55 m)	28 ft. 2 in. (8.58 m)
<b>B</b> Overall Height	9 ft. 5 in. (2.87 m)	10 ft. 2 in. (3.11 m)
<b>C</b> Rear-End Length/Swing Radius	8 ft. 2 in. (2.49 m)	
<b>D</b> Distance Between Idler/Sprocket Centerline	10 ft. 2 in. (3.10 m)	
<b>E</b> Undercarriage Length	12 ft. 10 in. (3.92 m)	
<b>F</b> Counterweight Clearance	3 ft. 3 in. (1001 mm)	
<b>G</b> Upperstructure Width	8 ft. 2 in. (2.48 m)	
<b>H</b> Cab Height	9 ft. 8 in. (2.95 m)	
<b>I</b> Track Width with Triple Semi-Grouser Shoes	24 in. (600 mm) / 28 in. (700 mm)	
<b>J</b> Gauge Width	6 ft. 6 in. (1.99 m)	
<b>K</b> Ground Clearance	19 in. (470 mm)	
<b>L</b> Overall Width with Triple Semi-Grouser Shoes		
24 in. (600 mm)	8 ft. 6 in. (2.60 m)	
28 in. (700 mm)	8 ft. 10 in. (2.70 m)	

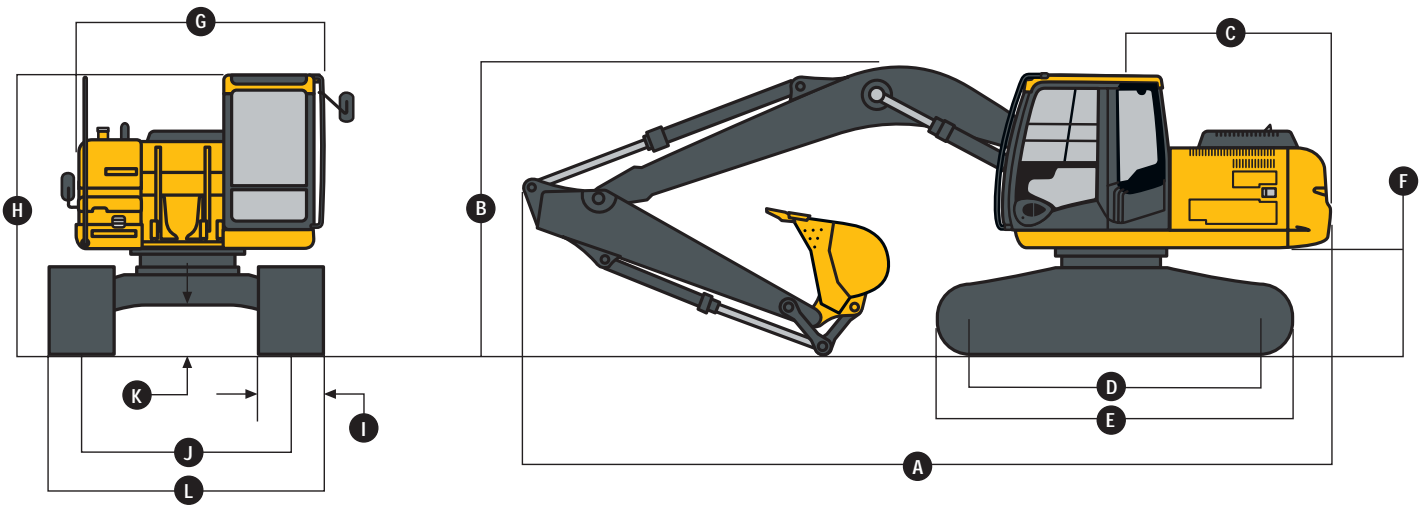

## Lift Charts

### 160D LC

**Boldface italic** type indicates hydraulic-limited capacities; lightface type indicates stability-limited capacities, in lb. (kg). Ratings are at bucket lift hook, using standard counterweight, situated on firm, level, uniform supporting surface. Figures do not exceed 87 percent of hydraulic capacity or 75 percent of weight needed to tip machine.

Load Point Height	5 ft. (1.52 m)		10 ft. (3.05 m)		15 ft. (4.57 m)		20 ft. (6.10 m)		25 ft. (7.62 m)	
	Over Front	Over Side	Over Front	Over Side	Over Front	Over Side	Over Front	Over Side	Over Front	Over Side
<i>With 8-ft. 6-in. (2.60 m) arm, 0.78-cu.-yd. (0.60 m<sup>3</sup>) bucket, and 24-in. (600 mm) triple semi-grouser shoes</i>										
20 ft. (6.10 m)							<b>5,470 (2481)</b>	<b>5,470 (2481)</b>		
15 ft. (4.57 m)							<b>6,568 (2979)</b>	6,411 (2908)		
10 ft. (3.05 m)					<b>9,265 (4203)</b>	<b>9,265 (4203)</b>	<b>7,684 (3485)</b>	6,107 (2770)	<b>5,803 (2632)</b>	4,073 (1847)
5 ft. (1.52 m)					<b>12,523 (5680)</b>	8,920 (4046)	<b>9,160 (4155)</b>	5,733 (2600)	6,443 (2922)	3,922 (1779)
Ground Line					14,137 (6412)	8,388 (3805)	8,959 (4064)	5,438 (2467)	6,300 (2858)	3,789 (1719)
-5 ft. (-1.52 m)			<b>13,758 (6241)</b>	<b>13,758 (6241)</b>	13,949 (6327)	8,226 (3731)	8,810 (3996)	5,302 (2405)		
-10 ft. (-3.05 m)	<b>18,000 (8165)</b>	<b>18,000 (8165)</b>	<b>16,758 (7601)</b>	16,167 (7333)	14,052 (6374)	8,315 (3772)	8,875 (4026)	5,361 (2432)		
-15 ft. (-4.57 m)			<b>15,450 (7008)</b>	<b>15,450 (7008)</b>	<b>10,825 (4910)</b>	8,315 (3772)				
<i>With 8-ft. 6-in. (2.60 m) arm, 0.78-cu.-yd. (0.60 m<sup>3</sup>) bucket, and 28-in. (700 mm) triple semi-grouser shoes</i>										
20 ft. (6.10 m)							<b>5,470 (2481)</b>	<b>5,470 (2481)</b>		
15 ft. (4.57 m)							<b>6,568 (2979)</b>	6,507 (2952)		
10 ft. (3.05 m)					<b>9,265 (4203)</b>	<b>9,265 (4203)</b>	<b>7,684 (3485)</b>	6,202 (2813)	<b>5,803 (2632)</b>	4,146 (1881)
5 ft. (1.52 m)					<b>12,523 (5680)</b>	9,057 (4108)	<b>9,160 (4155)</b>	5,829 (2644)	6,552 (2972)	3,995 (1812)
Ground Line					14,356 (6512)	8,525 (3867)	9,105 (4130)	5,534 (2510)	6,410 (2908)	3,862 (1752)
-5 ft. (-1.52 m)			<b>13,758 (6241)</b>	<b>13,758 (6241)</b>	14,169 (6427)	8,363 (3793)	8,956 (4062)	5,398 (2448)		
-10 ft. (-3.05 m)	<b>18,000 (8165)</b>	<b>18,000 (8165)</b>	<b>16,798 (7619)</b>	16,411 (7444)	<b>14,174 (6429)</b>	8,452 (3834)	9,021 (4092)	5,457 (2475)		
-15 ft. (-4.57 m)			<b>15,450 (7008)</b>	<b>15,450 (7008)</b>	<b>10,825 (4910)</b>	8,832 (4006)				

**Lift Charts (continued)**

**160D LC**

**Boldface italic** type indicates hydraulic-limited capacities; lightface type indicates stability-limited capacities, in lb. (kg). Ratings are at bucket lift hook, using standard counterweight, situated on firm, level, uniform supporting surface. Figures do not exceed 87 percent of hydraulic capacity or 75 percent of weight needed to tip machine.

Load Point Height	5 ft. (1.52 m)		10 ft. (3.05 m)		15 ft. (4.57 m)		20 ft. (6.10 m)		25 ft. (7.62 m)	
	Over Front	Over Side	Over Front	Over Side	Over Front	Over Side	Over Front	Over Side	Over Front	Over Side
<i>With 10-ft. 2-in. (3.10 m) arm, 0.52-cu.-yd. (0.40 m³) bucket, and 24-in. (600 mm) triple semi-grouser shoes</i>										
20 ft. (6.10 m)							<b>5,363 (2433)</b>	<b>5,363 (2433)</b>		
15 ft. (4.57 m)							<b>5,699 (2585)</b>	<b>5,699 (2585)</b>	<b>4,315 (1957)</b>	4,217 (1913)
10 ft. (3.05 m)					<b>7,960 (3611)</b>	<b>7,960 (3611)</b>	6,893 (3127)	6,180 (2803)	<b>6,172 (2800)</b>	4,100 (1860)
5 ft. (1.52 m)					<b>11,372 (5158)</b>	9,078 (4118)	<b>8,485 (3849)</b>	5,768 (2616)	6,441 (2922)	3,912 (1774)
Ground Line			<b>9,772 (4433)</b>	<b>9,772 (4433)</b>	<b>13,961 (6333)</b>	8,410 (3815)	8,948 (4059)	5,418 (2458)	6,254 (2837)	3,739 (1696)
-5 ft. (-1.52 m)	<b>7,754 (3517)</b>	<b>7,754 (3517)</b>	<b>14,078 (6386)</b>	<b>14,078 (6386)</b>	13,860 (6287)	8,133 (3689)	8,732 (3961)	5,222 (2369)	6,158 (2793)	3,649 (1655)
-10 ft. (-3.05 m)	<b>14,934 (6774)</b>	<b>14,934 (6774)</b>	<b>18,032 (8179)</b>	15,836 (7183)	13,869 (6291)	8,141 (3693)	8,719 (3955)	5,210 (2363)		
-15 ft. (-4.57 m)			<b>17,678 (8019)</b>	16,342 (7413)	<b>12,257 (5560)</b>	8,409 (3814)				
<i>With 10-ft. 2-in. (3.10 m) arm, 0.52-cu.-yd. (0.40 m³) bucket, and 28-in. (700 mm) triple semi-grouser shoes</i>										
20 ft. (6.10 m)							<b>5,363 (2433)</b>	<b>5,363 (2433)</b>		
15 ft. (4.57 m)							<b>5,699 (2585)</b>	<b>5,699 (2585)</b>	<b>4,315 (1957)</b>	4,290 (1946)
10 ft. (3.05 m)					<b>7,960 (3611)</b>	<b>7,960 (3611)</b>	<b>6,893 (3127)</b>	6,276 (2847)	<b>6,172 (2800)</b>	4,174 (1893)
5 ft. (1.52 m)					<b>11,372 (5158)</b>	9,216 (4180)	<b>8,485 (3849)</b>	5,864 (2660)	6,550 (2971)	3,985 (1808)
Ground Line			<b>9,772 (4433)</b>	<b>9,772 (4433)</b>	<b>11,372 (5158)</b>	8,547 (3877)	9,094 (4125)	5,513 (2501)	6,364 (2887)	3,812 (1729)
-5 ft. (-1.52 m)	<b>7,754 (3517)</b>	<b>7,754 (3517)</b>	<b>14,078 (6386)</b>	<b>14,078 (6386)</b>	13,961 (6333)	8,271 (3752)	8,878 (4027)	5,317 (2412)	6,268 (2843)	3,723 (1689)
-10 ft. (-3.05 m)	<b>14,934 (6774)</b>	<b>14,934 (6774)</b>	<b>18,032 (8179)</b>	16,080 (7294)	14,079 (6386)	8,279 (3755)	8,865 (4021)	5,305 (2406)		
-15 ft. (-4.57 m)			<b>17,678 (8019)</b>	16,586 (7523)	<b>12,257 (5560)</b>	8,547 (3877)				

**Buckets**

A full line of buckets is offered to meet a wide variety of applications. Digging forces are with power boost. Replaceable cutting edges are available through John Deere parts. Optional side cutters add 6 inches (150 mm) to bucket widths. Capacities are SAE heaped ratings.

Type Bucket	Bucket Width		Bucket Capacity		Weight		Bucket Dig Force		Arm Dig Force 8 ft. 6 in. (2.60 m)		Arm Dig Force 10 ft. 2 in. (3.10 m)		Bucket Tip Radius		No. Teeth
	in.	mm	cu. yd.	m³	lb.	kg	lb.	kN	lb.	kN	lb.	kN	in.	mm	
General-Purpose	24	610	0.54	0.41	1,081	491	20,920	93.1	18,804	83.6	16,808	74.8	57.61	1463	4
High Capacity	30	760	0.72	0.55	1,253	569	20,920	93.1	18,804	83.6	16,808	74.8	57.61	1463	4
	36	915	0.91	0.70	1,443	655	20,920	93.1	18,804	83.6	16,808	74.8	57.61	1463	5
	42	1065	1.11	0.85	1,615	733	20,920	93.1	18,804	83.6	16,808	74.8	57.61	1463	5
Heavy Duty	24	610	0.48	0.37	1,086	493	22,697	101.0	19,352	86.1	17,243	76.7	53.10	1349	4
	30	760	0.65	0.50	1,221	554	22,697	101.0	19,352	86.1	17,243	76.7	53.10	1349	4
	36	915	0.81	0.62	1,373	623	22,697	101.0	19,352	86.1	17,243	76.7	53.10	1349	5
	42	1065	0.99	0.76	1,508	685	22,697	101.0	19,352	86.1	17,243	76.7	53.10	1349	5
Ditching	60	1524	0.83	0.63	1,066	484	32,741	145.6	21,630	96.2	19,020	84.6	36.81	935	0

**Bucket Selection Guide\***

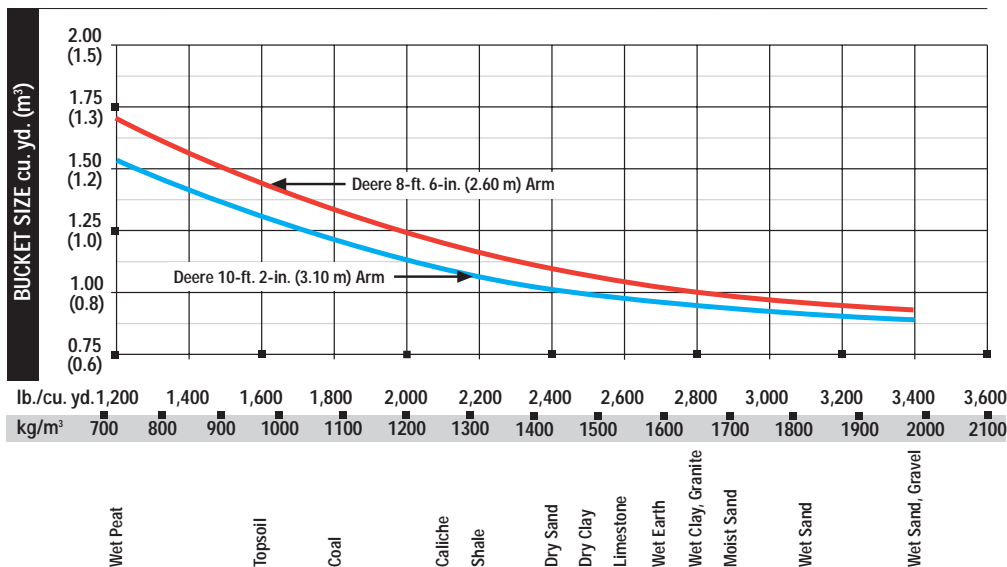

\*Contact your John Deere dealer for optimum bucket and attachment selections. These recommendations are for general conditions and average use. Does not include optional equipment such as thumbs or couplers. Larger buckets may be possible when using light materials, for flat and level operations, less compacted materials, and volume loading applications such as mass excavation applications in ideal conditions. Smaller buckets are recommended for adverse conditions such as off-level applications, rocks, and uneven surfaces. Bucket capacity indicated is SAE heaped.

## 160D LC EXCAVATOR

Key: ● Standard equipment ▲ Optional equipment

\*See your John Deere dealer for further information.

### 160D LC Engine

- Certified to EPA Tier 3 emissions
- Auto-idle system
- Automatic belt tension device
- Batteries (two 12 volt), 180-min. reserve capacity
- Coolant recovery tank
- Dual-element dry-type air filter
- Electronic engine control
- Enclosed fan guard (conforms to SAE J1308)
- Engine coolant to -34°F (-37°C)
- Fuel filter with water separator
- Full-flow oil filter
- Turbocharger with charge air cooler
- Muffler, under hood, with vertical curved end exhaust stack
- Cool-on-demand hydraulic-driven fan
- 500-hour engine oil-change interval
- 100% (45 deg.) off-level capability
- Engine-oil-sampling valve
- ▲ Hydraulic fan reverser
- ▲ Engine coolant heater

### Hydraulic System

- Reduced-drift valve for boom down, arm in
- Auxiliary hydraulic valve section
- Spring-applied, hydraulically released automatic swing brake
- Auxiliary hydraulic-flow adjustments through monitor
- Auto power lift
- 5,000-hour hydraulic oil-change interval
- Hydraulic-oil-sampling valve
- ▲ Auxiliary hydraulic lines
- ▲ Auxiliary pilot and electric controls
- ▲ Hydraulic filter restriction indicator kit
- ▲ Load-lowering control device
- ▲ Single-pedal propel control
- ▲ Control pattern-change valve

### Undercarriage

- Planetary drive with axial piston motors
- Propel motor shields
- Spring-applied, hydraulically released automatic propel brake
- Track guides, front idler and center
- Two-speed propel with automatic shift
- Upper carrier rollers (2)

### 160D LC Undercarriage (continued)

- Sealed and lubricated track chain
- ▲ Triple semi-grouser shoes, 24 in. (600 mm)
- ▲ Triple semi-grouser shoes, 28 in. (700 mm)

### Upperstructure

- Right- and left-hand mirrors
- Vandal locks with ignition key: Cab door / Fuel cap / Service doors / Toolbox
- Debris-screening side panel
- Remote-mounted engine oil and fuel filters

### Front Attachments

- Centralized lubrication system
- Dirt seals on all bucket pins
- Less boom and arm
- Oil-impregnated bushings
- Reinforced resin thrust plates
- Tungsten carbide thermal coating on arm-to-bucket joint
- ▲ Arm, 8 ft. 6 in. (2.60 m)
- ▲ Arm, 10 ft. 2 in. (3.10 m)
- ▲ Attachment quick-couplers
- ▲ Boom cylinder with plumbing to mainframe for less boom and arm
- ▲ Buckets: Ditching / Heavy duty / Heavy-duty high capacity / Side cutters and teeth
- ▲ Material clamps

### Operator's Station

- Adjustable independent control positions (levers-to-seat, seat-to-pedals)
- AM/FM radio
- Auto climate control/air conditioner, 20,000 Btu/hr. (5.9 kW), with heater and pressurizer
- Built-in operator's manual storage compartment and manual
- Cell-phone power outlet, 12 volt, 60 watt, 5 amp
- Coat hook
- Deluxe suspension cloth seat with 4-in. (100 mm) adjustable armrests
- Floor mat
- Front windshield wiper with intermittent speeds
- Gauges (illuminated): Engine coolant / Fuel
- Horn, electric
- Hour meter, electric
- Hydraulic shutoff lever, all controls
- Hydraulic warm-up control

### 160D LC Operator's Station (continued)

- Interior light
- Large cup holder
- Machine Information Center (MIC)
- Mode selectors (illuminated): Power modes – three / Travel modes – two with automatic shift / Work mode – one
- Multifunction, color LCD monitor with: Diagnostic capability / Multiple-language capabilities / Maintenance tracking / Clock / System monitoring with alarm features: Auto-idle indicator, engine air cleaner restriction indicator light, engine check, engine coolant temperature indicator light with audible alarm, engine oil pressure indicator light with audible alarm, low-alternator-charge indicator light, low-fuel indicator light, fault-code alert indicator, fuel-rate display, wiper-mode indicator, work-lights-on indicator, and work-mode indicator
- ▲ Monitor system with alarm features: Hydraulic oil filter restriction indicator light
- Motion alarm with cancel switch (conforms to SAE J994)
- Power-boost switch on right console lever
- Auxiliary hydraulic control switches in right console lever
- SAE two-lever control pattern
- Seat belt, 2 in. (51 mm), retractable
- ▲ Seat belt, 3 in. (76 mm), non-retractable
- Tinted glass
- Transparent tinted overhead hatch
- Hot/cold beverage compartment
- ▲ Air-suspension heated seat
- ▲ 24- to 12-volt D.C. radio converters, 10 amp
- ▲ Circulation fan
- ▲ Protection screens for cab front, rear, and side
- ▲ Window vandal protection covers

### Electrical

- 80-amp alternator
- Blade-type multi-fused circuits
- Positive terminal battery covers
- ▲ Cab extension wiring harness
- ▲ JDLink

### Lights

- Work lights: Halogen / One mounted on boom / One mounted on frame

## CONTROL OWNING AND OPERATING COSTS

Customer Personal Service (CPS) is part of John Deere's proactive, fix-before-fail strategy on machine maintenance that will help control costs, increase profits, and reduce stress. Included in this comprehensive lineup of ongoing programs and services are:

**Fluid analysis program** – tells you what's going on inside *all* of your machine's major components so you'll know if there's a problem *before* you see a decline in performance. Fluid analysis is included in most extended coverage and preventive-maintenance agreements.

**Component life-cycle data** – gives you vital information on the projected life span of components and lets you make informed decisions on machine maintenance by telling you approximately how many hours of use you can expect from an engine, transmission, or hydraulic pump. This information can be used to preempt catastrophic downtime by servicing major components at about 80 percent of their life cycle.

**Preventive Maintenance (PM) agreements** – give you a fixed cost for maintaining a machine for a given period of time. They also help you avoid downtime by ensuring that critical

maintenance work gets done right and on schedule. On-site preventive maintenance service performed where and when you need it helps protect you from the expense of catastrophic failures and lets you avoid waste-disposal hassles.

**Extended coverage** – gives you a fixed cost for machine repairs for a given period of time so you can effectively manage costs. Whether you work in a severe-service setting or just want to spread the risk of doing business, this is a great way to custom-fit coverage for your operation. And an extended coverage contract also travels well because it's backed by John Deere and is honored by *all* Deere construction dealers.

**Customer Support Advisors (CSAs)** – Deere believes the CSA program lends a *personal* quality to Customer Personal Service (CPS). Certified CSAs have the knowledge and skills for helping make important decisions on machine maintenance and repair. Their mission is to help you implement a plan that's right for *your* business and take the burden of machine maintenance off your shoulders.



JOHN DEERE

DKAX160DLC Litho in U.S.A. (07-05)

Net engine power is with standard equipment including air cleaner, exhaust system, alternator, and cooling fan at test conditions per ISO9249. No derating is required up to 10,000-ft. (3050 m) altitude.

Specifications and design subject to change without notice. Wherever applicable, specifications are in accordance with SAE standards. Except where otherwise noted, these specifications are based on a unit with 28-in. (700 mm) triple semi-grouser shoes; 10-ft. 2-in. (3.10 m) arm; 36-in. (914 mm), 0.81-cu. yd. (0.62 m<sup>3</sup>), 1,373-lb. (623 kg) heavy-duty bucket; 7,275-lb. (3300 kg) counterweight; full fuel tank; and 175-lb. (79 kg) operator.

